

EXPERIMENTAL STUDY OF HEAT TRANSFER
DURING THE BOILING OF OXYGEN IN
VERTICAL CHANNELS WITH
CONDENSATION HEATING

S. N. Shorin, V. I. Sukhov,
S. A. Shevyakova, and V. K. Orlov

UDC 536.423

The results of an experimental investigation into heat transfer taking place during the boiling of oxygen in vertical channels under natural circulation are presented. A relationship generalizing the experimental data is proposed.

The complexity of heat-transfer in air-separating installations of the condenser-evaporator type lies in the fact that the condensation and boiling of low-temperature working media such as oxygen and nitrogen take place under small temperature heads and are mutually related to one another. Oxygen boils with a reduced level of the liquid in the down pipe, and the vapor-generating tubes have to allow free flow in order to avoid operating conditions leading to explosions.

Heat transfer associated with the boiling of oxygen and nitrogen on and within vertical pipes was studied under conditions of electric heating in [1-4]; in condenser-evaporators the boiling of oxygen or any other liquid takes place under conditions of condensation heating.

The functional relationships obtained in [1, 3] were used as a basis for the thermal calculation of condenser-evaporators in [5]. The substantial systematic differences which arise between the theoretical and experimental heat flow densities [6] demand a redetermination of the heat transfer associated with the boiling of oxygen in vertical channels.

In this paper we shall present the results of an investigation into the heat transfer associated with the boiling of oxygen under conditions of condensation heating. The experiments were carried out in tubular and plate-fin models of condenser-evaporators under almost industrial conditions. The basic principles of the models are indicated in Figs. 1 and 2; the experimental test-bed was described in [9].

The tubular models consisted of 46 copper vapor-generating tubes 12×1.5 mm in diameter, the tube lengths being 1.46 and 2.94 m respectively. In the side of one of the vapor-generating tubes was a multiple copper-Constantan thermocouple enabling the temperature of the wall to be measured at nine points up and down the tube. In another tube was a multiple thermocouple for measuring the temperature of the vapor-liquid flow at eleven points up and down the experimental section. The temperature of the boiling medium was measured at the tube inlet and outlet. The temperature drops between the outlet and any of the points of the multiple thermocouples were measured by a differential method. The thermo-emf was measured with an R-306 potentiometer together with a mirror galvanometer of the M 195/1 type and a normal mercury cell. The accuracy of the temperature-drop measurements was ± 0.07 deg.

The plate-fin condenser-evaporator consisted of two packs made from the aluminum alloy AMtsS by soldering in a flux melt. The length of the vapor-generating channels was 1.625 m, the dimensions of the fin stack $6 \times 4.22 \times 0.22$ mm. The constructions of plate-fin condenser-evaporators in air-separating installations were considered in [12].

The experimental models were placed in a thermostat and this was filled with liquid oxygen up to a specified level.

Translated from *Inzhenerno-Fizicheskii Zhurnal*, Vol. 25, No. 5, pp. 773-779, November, 1973.
Original article submitted June 14, 1973.

© 1975 Plenum Publishing Corporation, 227 West 17th Street, New York, N.Y. 10011. No part of this publication may be reproduced, stored in a retrieval system, or transmitted, in any form or by any means, electronic, mechanical, photocopying, microfilming, recording or otherwise, without written permission of the publisher. A copy of this article is available from the publisher for \$15.00.

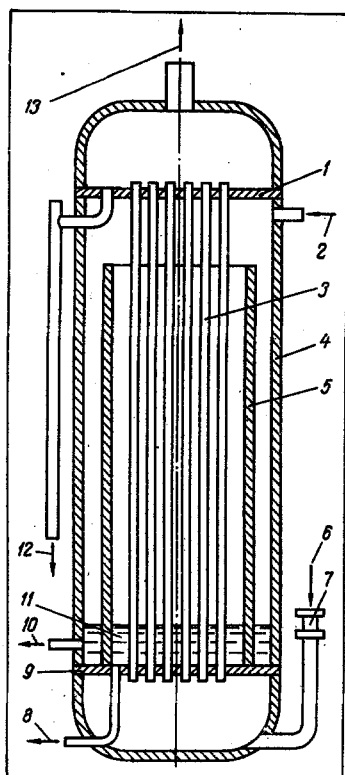

Fig. 1

Fig. 1. Arrangement of the tubular models of a condenser-evaporator: 1) upper tube grid; 2) inlet of nitrogen for condensation; 3) vapor-generating tubes; 4) outer casing; 5) inner casing; 6) inlet for boiling oxygen; 7) liquid flowmeter; 8) condensate outlet; 9) lower tube grid; 10) condensate outlet; 11) level of condensate; 12) outlet of circulating oxygen; 13) outlet of oxygen vapor.

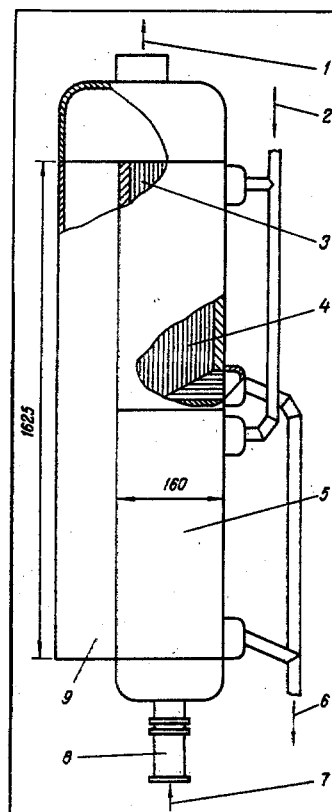

Fig. 2

Fig. 2. Arrangement of the plate-fin model of a condenser-evaporator: 1) outlet of oxygen vapor; 2) inlet of nitrogen for condensation; 3) vapor-generating channel; 4) condensation channel; 5) plate-fin pack; 6) condensate outlet; 7) boiling oxygen inlet; 8) liquid flowmeter; 9) down system of circulating circuit.

The heat carrier in these experiments was condensing nitrogen, the heat-receiving medium was oxygen. In the tubular models condensation took place in the intertube space, and boiling occurred between the tubes; in the plate-fin apparatus these changes took place in the boiling and condensation channels respectively. The heat evolved on condensation was taken up by the oxygen. In the vapor-generating channels and tubes, the circulation of the boiling liquid began under the influence of the ponderomotive pressure head; its velocity was measured with a flowmeter of the turbine type and varied from 0.03 to 0.35 m/sec. The circulating liquid poured from the upper grids into the main volume of the liquid oxygen along the down pipes. The heat flow density was determined from the amount of condensate and equalled 600–4500 W/m². The level of the condensate was kept constant during the experiments, in the tubular models in the intertube space, and in the plate-fin models in the condensate collector.

The experiments were carried out over a wide range of operating parameters, corresponding to those encountered in industrial systems. Thus the pressure of the boiling medium had three values, 1.225, 1.4, and 1.55 bar; the relative level of the oxygen in the down pipe varied from 0.3 to 0.9 of the working length of the vapor-generating channels.

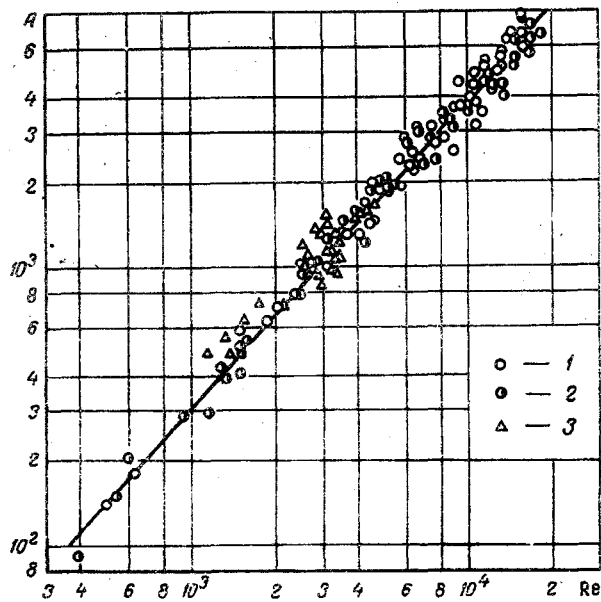

Fig. 3

Fig. 3. Experimental data regarding the boiling of oxygen in vertical channels ($A = ((1/Q/M\Delta h) - 1)(Qd/F\rho^m r\nu)^{0.75}(l/d)^{1.1}$; $Re = w_0 d/\nu$): 1) Tubular model 1.46 m long; 2) tubular model 2.94 m long; 3) plate-fin model.

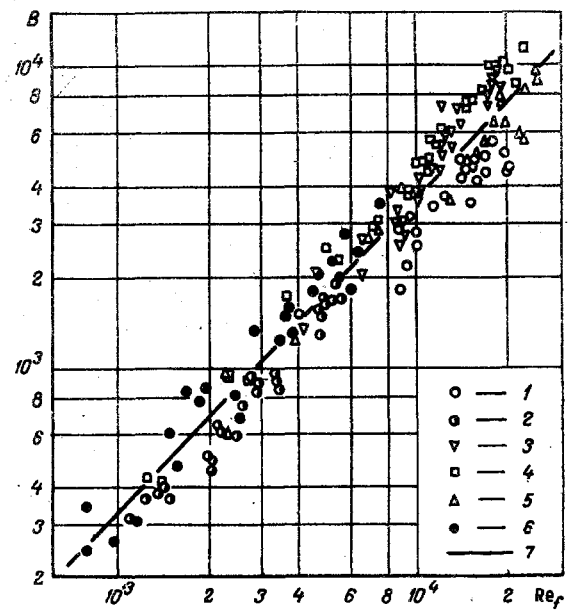

Fig. 4

Fig. 4. Experimental data of [10, 11] regarding the boiling of oxygen in vertical tubes ($B = (1/K_T) - 1)Re_F^{0.75}(l/d)^{1.1}$): 1) tube $l = 5$ m; $d = 9$ mm [11]; 2) $l = 1.81$ m, $d = 4$ mm [11]; 3) $l = 1$ m; $d = 7.6$ mm [11]; 4) $l = 1.81$ m; $d = 9$ mm [11]; 5) $l = 1.02$ m; $d = 9.6$ mm [11]; 6) tube $l = 2.4$ m, $d = 8$ mm [10]; 7) Eq. (8).

A generalized expression was derived for the experimental data relating to the intensity of heat transfer while boiling, using the integrated characteristics of heat-transfer.

The energy balance in the vapor-generating channels corresponds to

$$\int_{(F)} q_{\text{trans.}} n dF = \int_1^2 q_{\text{conv.}} n df. \quad (1)$$

The integrals in (1) may be expressed in the following form:

$$\int_{(F)} q_{\text{trans.}} n dF = F \langle w\rangle_F (\langle \Delta h \rangle_F - \langle \Delta h \rangle_1), \quad (2)$$

$$\int_1^2 q_{\text{conv.}} n df = (\Sigma M_i) (\langle \Delta h \rangle_2 - \langle \Delta h \rangle_1). \quad (3)$$

Allowing for (2) and (3), Eq. (1) may be written in the form

$$F \langle w\rangle_F (\langle \Delta h \rangle_F - \langle \Delta h \rangle_1) = (\Sigma M_i) (\langle \Delta h \rangle_2 - \langle \Delta h \rangle_1). \quad (4)$$

From this we obtain the integrated criterion of energy transfer in the vapor-generating channel

$$K_T = \frac{F \langle w\rangle_F}{\Sigma M_i} = \frac{Q}{(\Sigma M_i) (\langle \Delta h \rangle_F - \langle \Delta h \rangle_1)} = \frac{Q}{M [c_p (\bar{T}_F - T'_j) + xr]}. \quad (5)$$

The energy-transfer criterion constitutes the ratio of the actual heat transfer from the wall to the maximum possible heat transfer in the final thermodynamic state of the flow at the wall temperature.

An analysis of the equations (the conservation equations of the transfer properties and the boundary conditions) enables us to obtain the argumental quantities (numbers), which in general determine the intensity of heat transfer during the boiling of the liquid in the channels. As a result of such an analysis we obtain the following functional relationship for the integrated heat-transfer criterion

$$K_T = f(Re_F, Re_F, l/d, Pr, Fr, We, C). \quad (6)$$

The experimental data obtained in the tubular condenser-evaporators were analyzed using the first three argumental numbers Re_f , Re_F , l/d in (6). As a result of the calculations we obtained a functional relationship for the integrated criterion of heat transfer, without detecting any influence of the Froude and Weber numbers, which under the experimental conditions varied over a wide range. Any influence of the Prandtl number could not validly be inferred, since in our experiments it only varied a little and remained around 1.9.

The thermophysical properties of oxygen were taken from [8] at the saturation temperature corresponding to the pressure and oxygen concentration in the vapor over the boiling liquid. An exception was the vapor density, which was calculated from the saturation temperature at the mean pressure in the vapor-generating channels. The mass flow of vapors was referred to the heat-transfer surface, i.e., to the surface above the level of the condensate.

The temperature head of the heat transfer associated with boiling was found as the difference between the mean temperature of the tube walls and the temperature of the liquid at the inlet into the vapor-generating tube, which, as indicated by the temperature measurements, was equal to the saturation temperature at the pressure and concentration of the vapor at the outlet from the tubes. The average wall temperature was found by integrating the temperatures measured in the experiments

$$\bar{T}_F = \frac{1}{l} \int T_F dl. \quad (7)$$

The geometrical characteristics of the channel included the total length and equivalent diameter.

The results of our generalization correlation of the data are presented in Fig. 3. The experimental data obtained in the tubular models may be approximated to an accuracy of 20% by the relationship

$$K_T = \frac{1}{1 + 0.15 Re_f^{1.1} Re_F^{-0.75} (l/d)^{-1.1}}. \quad (8)$$

Equation (8) was used for calculating the heat transfer associated with boiling in the plate-fin condenser-evaporator. The results of the calculation are also shown in Fig. 3. In determining the integrated criterion of heat transfer, the temperature of the wall was found by calculating the condensation process as in [8] for the low-mobility vapor, since we were unable to measure this quantity experimentally. The validity of this application of the relationship given in [8] for calculating the condensation of nitrogen was verified by analyzing the condensation data obtained in the tubular models of the condenser-evaporator.

No perceptible influence of the material composing the heat-transfer surface (copper and aluminum alloy AMtsS) on the heat transfer associated with the boiling of the oxygen in the channels under conditions of natural circulation was observed.

The experimental data of [10, 11] were calculated in the form of the complexes indicated in Eq. (8). Since the papers in question gave no data regarding the absolute temperatures of the heat-transmitting surface and the boiling medium, we used the temperature heads corresponding to the interpretation of the authors of [10, 11] in this calculation. The experimental material of [11] was very wide. In connection with our own investigations we used 108 experiments in the heat-flow range 1160-9300 W/m². The results of the calculation are presented in Fig. 4. The experimental data of [10,11] agree satisfactorily with Eq. (8). The deviation of the points from the proposed relationship is no greater than ±35%.

Thus Eq. (8) may be recommended for calculating heat transfer during the boiling of low-temperature liquids in vertical channels under conditions of natural circulation of the boiling medium.

NOTATION

$K_T \equiv Q/M\Delta h$	is the integrated heat-transfer criterion (number);
$Re_f \equiv w_0 d / \nu$	is the Reynolds number of the flow of liquid at the inlet into the vapor-generating channels;
$Re_F \equiv Q / F \rho^n r \nu$	is the modified Reynolds number of the mass flow to the heat-transfer surface;
Q	is the heat-transfer power, W;
M	is the mass flow of circulating liquid, kg/sec;
$\Delta h = c_p \Delta T + x r$	is the enthalpy difference of heat transfer, J/kg;
$\Delta T = \bar{T}_F - T'_f$	is the temperature head, deg;
c_p	is the specific heat of liquid oxygen, J/kg · deg;

r	is the energy of liquid-vapor phase transition, J/kg;
$x = Q/Mr$	is the gravimetric vapor content at the outlet from the vapor-generating channels;
\bar{T}_F	is the mean channel wall temperature, °K;
T_f	is the oxygen temperature at the inlet into the channels, °K;
w_0	is the mean velocity of the liquid oxygen at the inlet into the channels, m/sec;
d	is the equivalent channel diameter, m;
ν	is the kinematic viscosity of the liquid oxygen, m ² /sec;
F	is the area of the heat-transfer surface, m ² ;
ρ''	is the oxygen vapor density, kg/m ³ ;
l	is the length of channels, m;
f	is the area of cross section, m ² ;
$\langle w\rho \rangle_F$	is the average nominal mass velocity of energy transfer to the wall, kg/sec · m ² ;
$\langle \Delta h \rangle$	is the average total enthalpy of unit mass of the flow, J/kg · deg;
ΣM_i	is the intensity of the mass flow, kg/sec;
$q_{conv.n}$	is the flow density of convective heat transfer, W/m ² ;
$q_{trans.n}$	is the density of heat flow received by the boiling liquid from the wall, W/m ² .

LITERATURE CITED

1. M. E. Ivanov and N. K. Elukhin, *Kislород*, No. 8, 19-28 (1959).
2. N. K. Elukhin and I. P. Vishnev, *Kislород*, No. 4, 5-15 (1959).
3. I. P. Vishnev and N. K. Elukhin, *Trudy VNIKIMASH*, Moscow, No. 3, 85 (1960).
4. I. P. Vishnev and N. K. Elukhin, *Trudy VNIKIMASH*, Moscow, No. 6, 44 (1963).
5. N. K. Elukhin and I. P. Vishnev, *Trudy VNIKIMASH*, Moscow, No. 7 (1963).
6. V. I. Sukhov, V. K. Orlov, and S. A. Shevyakova, *TsINTIKhIMNESFTEMASH*, Moscow (1971) (deposited article No. 3345).
7. A. A. Vasserman, Ya. Z. Kazavchinskii, and V. A. Rabinovich, *Thermophysical Properties of Air and Its Components* [in Russian], Nauka, Moscow (1966).
8. D. A. Labuntsov, *Teploénergetika*, No. 7, 72-80 (1957).
9. V. I. Sukhov, V. K. Orlov, and S. A. Shevyakova, *Kislородnaya Prom.*, No. 1, 25-32 (1970).
10. M. E. Ivanov, *Candidate's Dissertation*, Moscow Institute of Chemical Engineering [in Russian], Moscow (1956).
11. I. P. Vishnev, *Candidate's Dissertation*, Moscow Institute of Chemical Engineering [in Russian], Moscow (1959).
12. *Lamellar Heat Exchangers of Air-Separating Installations* [in Russian], *TsINTIKhIMNESFTEMASH*, Moscow (1972).